

10. ENERGY EFFICIENT TECHNOLOGIES IN ELECTRICAL SYSTEMS

Syllabus

Energy Efficient Technologies in Electrical Systems: Maximum demand controllers, Automatic power factor controllers, Energy efficient motors, Soft starters with energy saver, Variable speed drives, Energy efficient transformers, Electronic ballast, Occupancy sensors, Energy efficient lighting controls, Energy saving potential of each technology.

10.1. Maximum Demand Controllers

High-tension (HT) consumers have to pay a maximum demand charge in addition to the usual charge for the number of units consumed. This charge is usually based on the highest amount of power used during some period (say 30 minutes) during the metering month. The maximum demand charge often represents a large proportion of the total bill and may be based on only one isolated 30 minute episode of high power use.

Considerable savings can be realised by monitoring power use and **turning off or reducing non-essential loads** during such periods of high power use.

Maximum Demand Controller (See Figure 10.1) is a device designed to meet the need of industries conscious of the value of load management. Alarm is sounded when demand approaches a preset value. If corrective action is not taken, the controller switches off non-essential loads in a logical sequence. This sequence is predetermined by the user and is programmed jointly by the user and the supplier of the device. The plant equipments selected for the load management are

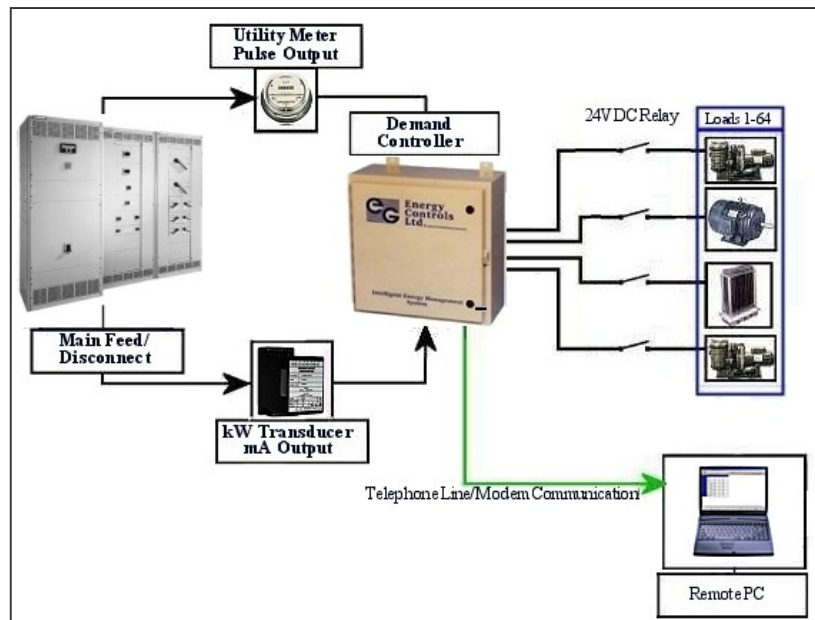

Figure 10.1 Maximum Demand Controller

stopped and restarted as per the desired load profile. Demand control scheme is implemented by using suitable control contactors. Audio and visual annunciations could also be used.

10.2 Automatic Power Factor Controllers

Various types of automatic power factor controls are available with relay / microprocessor logic. Two of the most common controls are: Voltage Control and kVAr Control

Voltage Control

Voltage alone can be used as a source of intelligence when the switched capacitors are applied at point where the circuit voltage decreases as circuit load increases. Generally, where they are applied the voltage should decrease as circuit load increases and the drop in voltage should be around 4 – 5 % with increasing load.

Voltage is the most common type of intelligence used in substation applications, when maintaining a particular voltage is of prime importance. This type of control is independent of load cycle. During light load time and low source voltage, this may give leading PF at the substation, which is to be taken note of.

KILOVAR Control

Kilovar sensitive controls (see Figure 10.2) are used at locations where the voltage level is closely regulated and not available as a control variable. The capacitors can be switched to respond to a decreasing power factor as a result of change in system loading. This type of control can also be used to avoid penalty on low power factor by adding capacitors in steps as the system power factor begins to lag behind the desired value. Kilovar control requires two inputs - current and voltage from the incoming feeder, which are fed to the PF correction mechanism, either the microprocessor or the relay.

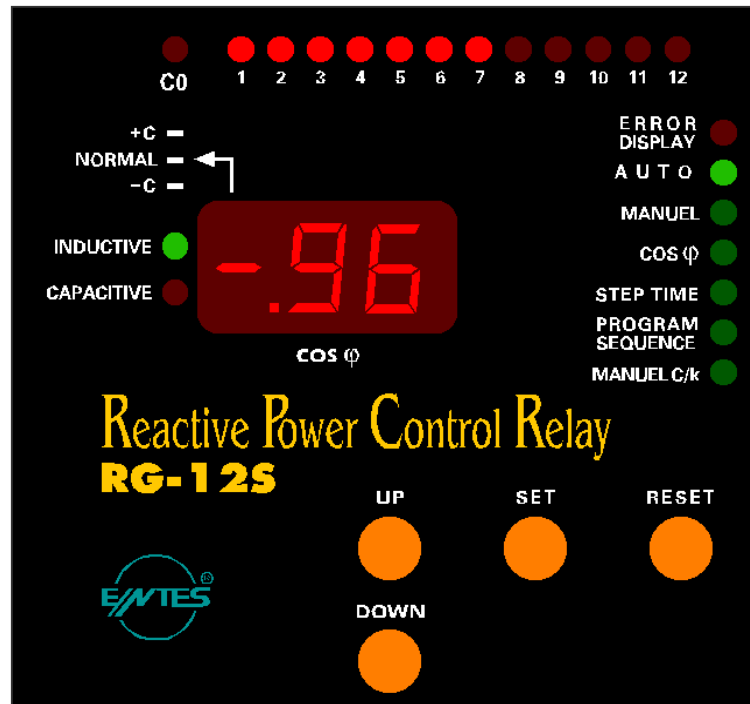

Figure 10.2

Automatic Power Factor Control Relay

It controls the power factor of the installation by giving signals to switch on or off power factor correction capacitors. Relay is the brain of control circuit and needs contactors of appropriate rating for switching on/off the capacitors.

There is a built-in power factor transducer, which measures the power factor of the installation and converts it to a DC voltage of appropriate polarity. This is compared with a reference voltage, which can be set by means of a knob calibrated in terms of power factor.

When the power factor falls below setting, the capacitors are switched on in sequence. The relays are provided with First in First out (FIFO) and First in Last Out (FILO) sequence. The capacitors controlled by the relay must be of the same rating and they are switched on/off in linear sequence. To prevent over correction hunting, a dead band is provided. This setting determines the range of phase angle over which the relay does not respond; only when the PF goes beyond this range, the relay acts. When the load is low, the effect of the capacitors is more pronounced and may lead to hunting. Under current blocking (low current cut out) shuts off the relay, switching off all capacitors one by one in sequence, when load current is below setting. Special timing sequences ensure that capacitors are fully discharged before they are switched in. This avoids dangerous over voltage transient. The solid state indicating lamps (LEDS) display various functions that the operator should know and also indicate each capacitor switching stage.

Intelligent Power Factor Controller (IPFC)

This controller determines the rating of capacitance connected in each step during the first hour of its operation and stores them in memory. Based on this measurement, the IPFC switches on the most appropriate steps, thus eliminating the hunting problems normally associated with capacitor switching.

10.3 Energy Efficient Motors

Minimising Watts Loss in Motors

Improvements in motor efficiency can be achieved without compromising motor performance - at higher cost - within the limits of existing design and manufacturing technology.

From the Table 10.1, it can be seen that any improvement in motor efficiency must result from reducing the Watts losses. In terms of the existing state of electric motor technology, a reduction in watts losses can be achieved in various ways.

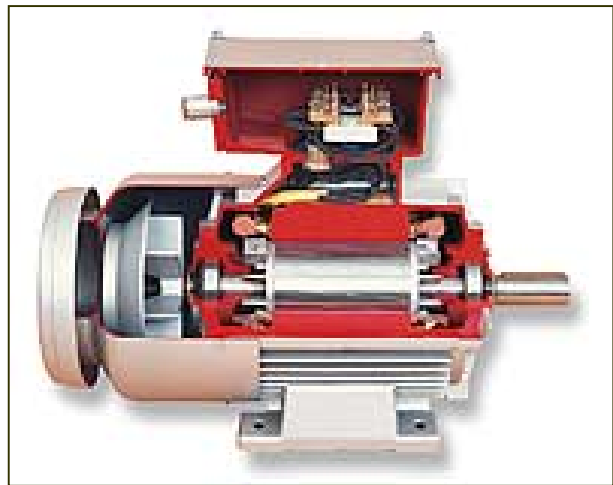

Figure 10.3 Energy Efficient Motor

All of these changes to reduce motor losses are possible with existing motor design and manufacturing technology. They would, however, require additional materials and/or the use of higher quality materials and improved manufacturing processes resulting in increased motor cost.

Simply Stated: REDUCED LOSSES = IMPROVED EFFICIENCY

Table 10.1 Watt Loss Area and Efficiency Improvement	
Watts Loss Area	Efficiency Improvement
1. Iron	Use of thinner gauge, lower loss core steel reduces eddy current losses. Longer core adds more steel to the design, which reduces losses due to lower operating flux densities.
2. Stator $I^2 R$	Use of more copper and larger conductors increases cross sectional area of stator windings. This lowers resistance (R) of the windings and reduces losses due to current flow (I).
3. Rotor $I^2 R$	Use of larger rotor conductor bars increases size of cross section, lowering conductor resistance (R) and losses due to current flow (I).
4. Friction & Windage	Use of low loss fan design reduces losses due to air movement.
5. Stray Load Loss	Use of optimised design and strict quality control procedures minimizes stray load losses.

Thus energy-efficient electric motors reduce energy losses through improved design, better materials, and improved manufacturing techniques. Replacing a motor may be justifiable solely on the electricity cost savings derived from an energy-efficient replacement. This is true if the motor runs continuously, power rates are high, the motor is oversized for the application, or its nominal efficiency has been reduced by damage or previous rewinds. Efficiency comparison for standard and high efficiency motors is shown in Figure 10.4

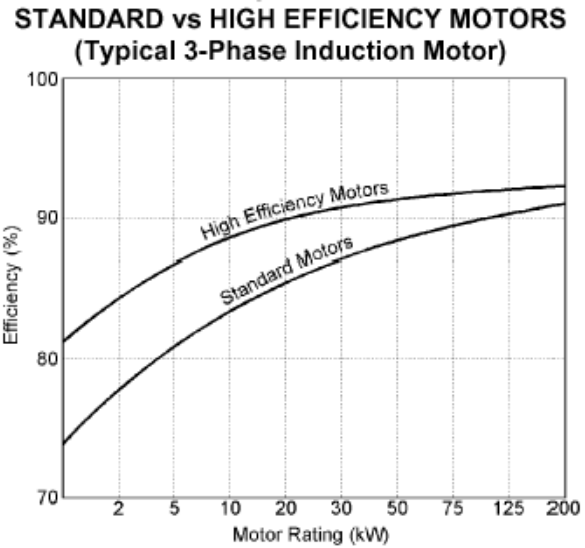

Figure 10.4 Efficiency Range for Standard and High Efficiency Motors

Technical aspects of Energy Efficient Motors

Energy-efficient motors last longer, and may require less maintenance. At lower temperatures, bearing grease lasts longer; required time between re-greasing increases. Lower temperatures translate to long lasting insulation. Generally, motor life doubles for each 10°C reduction in operating temperature.

Select energy-efficient motors with a 1.15 service factor, and design for operation at 85% of the rated motor load.

Electrical power problems, especially poor incoming power quality can affect the operation of energy-efficient motors.

Speed control is crucial in some applications. In polyphase induction motors, slip is a measure of motor winding losses. The lower the slip, the higher the efficiency. Less slippage in energy efficient motors results in speeds about 1% faster than in standard counterparts.

Starting torque for efficient motors may be lower than for standard motors. Facility managers should be careful when applying efficient motors to high torque applications.

10.4 Soft Starter

When starting, AC Induction motor develops more torque than is required at full speed. This stress is transferred to the mechanical transmission system resulting in excessive wear and premature failure of chains, belts, gears, mechanical seals, etc. Additionally, rapid acceleration also has a massive impact on electricity supply charges with high inrush currents drawing +600% of the normal run current.



Figure 10.5 Soft Starter

The use of Star Delta only provides a partial solution to the problem. Should the motor slow down during the transition period, the high peaks can be repeated and can even exceed direct on line current.

Soft starter (see Figure 10.5) provides a reliable and economical solution to these problems by delivering a controlled release of power to the motor, thereby providing smooth, stepless acceleration and deceleration. Motor life will be extended as damage to windings and bearings is reduced.

Soft Start & Soft Stop is built into 3 phase units, providing controlled starting and stopping with a selection of ramp times and current limit settings to suit all applications (see Figure 10.6).

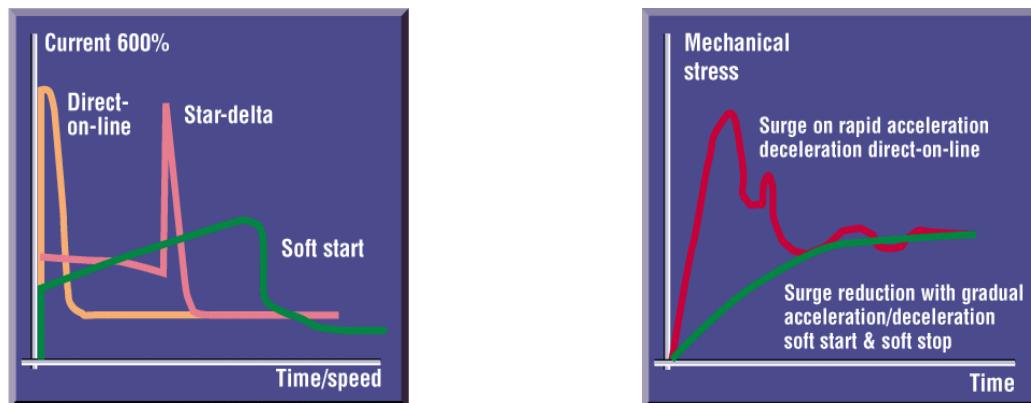

Figure 10.6 Soft Starter: Starting current, Stress profile during starting

Advantages of Soft Start

- Less mechanical stress
- Improved power factor.
- Lower maximum demand.
- Less mechanical maintenance

10.5 Variable Speed Drives

Speed Control of Induction Motors

Induction motor is the workhorse of the industry. It is cheap rugged and provides high power to weight ratio. On account of high cost-implications and limitations of D.C. System, induction motors are preferred for variable speed application, the speed of which can be varied by changing the supply frequency. The speed can also be varied through a number of other means, including, varying the input voltage, varying the resistance of the rotor circuit, using multi speed windings, using *Scherbius* or *Kramer* drives, using mechanical means such as gears and pulleys and eddy-current or fluid coupling, or by using rotary or static voltage and frequency converters.

Variable Frequency Drive

The VFD operates on a simple principle. The rotational speed of an AC induction motor depends on the number of poles in that stator and the frequency of the applied AC power. Although the number of poles in an induction motor cannot be altered easily, variable speed can be achieved through a variation in frequency. The VFD rectifies standard 50 cycle AC line power to DC, then synthesizes the DC to a variable frequency AC output.

Motors connected to VFD provide variable speed mechanical output with high efficiency. These devices are capable of up to a 9:1 speed reduction ratio (11 percent of full speed), and a 3:1 speed increase (300 percent of full speed).

In recent years, the technology of AC variable frequency drives (VFD) has evolved into highly sophisticated digital microprocessor control, along with high switching frequency IGBTs (Insulated Gate Bi Polar Transistors) power devices. This has led to significantly advanced capabilities from the ease of programmability to expanded diagnostics. The two most significant benefits from the evolution in technology have been that of cost and reliability, in addition to the significant reduction in physical size.

Variable Torque Vs. Constant Torque

Variable speed drives, and the loads that are applied to, can generally be divided into two groups: constant torque and variable torque. The energy savings potential of variable torque applications is much greater than that of constant torque applications. Constant torque loads include vibrating conveyors, punch presses, rock crushers, machine tools, and other applications where the drive follows a constant V/Hz ratio. Variable torque loads include centrifugal pumps and fans, which make up the majority of HVAC applications.

Why Variable Torque Loads Offer Greatest Energy Savings

In variable torque applications, the torque required varies with the square of the speed, and the horsepower required varies with the cube of the speed, resulting in a large reduction of horsepower for even a small reduction in speed. The motor will consume only 12.5% as much energy at 50% speed than it will at 100% speed. This is referred to as the **Affinity Laws**, which define the relationships between speed, flow, torque, and horsepower. The following laws illustrates these relationships:

- ❖ Flow is proportional to speed
- ❖ Head is proportional to (speed)²

- ❖ Torque is proportional to (speed)²
- ❖ Power is proportional to (speed)³

Tighter process control with variable speed drives

No other AC motor control method compares to variable speed drives when it comes to accurate process control. Full-voltage (across the line) starters can only run the motor at full speed, and soft starts and reduced voltage soft starters can only gradually ramp the motor up to full speed, and back down to shutdown. Variable speed drives, on the other hand, can be programmed to run the motor at a precise speed, to stop at a precise position, or to apply a specific amount of torque.

In fact, modern AC variable speed drives are very close to the DC drive in terms of fast torque response and speed accuracy. However, AC motors are much more reliable and affordable than DC motors, making them far more prevalent.

Most drives used in the field utilize Volts/Hz type control, which means they provide open-loop operation. These drives are unable to retrieve feedback from the process, but are sufficient for the majority of variable speed drive applications. Many open-loop variable speed drives do offer slip compensation though, which enables the drive to measure its output current and estimate the difference in actual speed and the set point (the programmed input value). The drive will then automatically adjust itself towards the set point based on this estimation.

Most variable torque drives have Proportional Integral Differential (PID) capability for fan and pump applications, which allows the drive to hold the set point based on actual feedback from the process, rather than relying on estimation. A transducer or transmitter is used to detect process variables such as pressure levels, liquid flow rate, air flow rate, or liquid level. Then the signal is sent to a PLC (Programmable Logic Controllers), which communicates the feedback from the process to the drive. The variable speed drive uses this continual feedback to adjust itself to hold the set point.

High levels of accuracy for other applications can also be achieved through drives that offer closed-loop operation. Closed-loop operation can be accomplished with either a field-oriented vector drive, or a sensor less vector drive. The field-oriented vector drive obtains process feedback from an encoder, which measures and transmits to the drive the speed and/or rate of the process, such as a conveyor, machine tool, or extruder. The drive then adjusts itself accordingly to sustain the programmed speed, rate, torque, and/or position.

Extended equipment life and reduced maintenance

Single-speed starting methods start motors abruptly, subjecting the motor to a high starting torque and to current surges that are up to 10 times the full-load current. Variable speed drives, on the other hand, gradually ramp the motor up to operating speed to lessen mechanical and electrical stress, reducing maintenance and repair costs, and extending the life of the motor and the driven equipment.

Soft starts, or reduced-voltage soft starters (RVSS), are also able to step a motor up gradually, but drives can be programmed to ramp up the motor much more gradually and smoothly, and can operate the motor at less than full speed to decrease wear and tear. Variable speed drives can also run a motor in specialized patterns to further minimise mechanical and electrical stress. For example, an S-curve pattern can be applied to a

conveyor application for smoother control, which reduces the backlash that can occur when a conveyor is accelerating or decelerating.

Typical full-load efficiencies are 95% and higher. High power units are still more efficient. The efficiency of VSDs generally decreases with speed but since the torque requirement also decreases with speed for many VSD applications, the absolute loss is often not very significant. The power factor of a VSD drops drastically with speed, but at low power requirement the absolute kVAR requirement is low, so the loss is also generally not significant. In a suitable operating environment, frequency controllers are relatively reliable and need little maintenance. A disadvantage of static converters is the generation of harmonics in the supply, which reduces motor efficiency and reduces motor output – in some cases it may necessitate using a motor with a higher rating.

Eddy Current Drives

This method employs an eddy-current clutch to vary the output speed. The clutch consists of a primary member coupled to the shaft of the motor and a freely revolving secondary member coupled to the load shaft. The secondary member is separately excited using a DC field winding. The motor starts with the load at rest and a DC excitation is provided to the secondary member, which induces eddy-currents in the primary member. The interaction of the fluxes produced by the two currents gives rise to a torque at the load shaft. By varying the DC excitation the output speed can be varied to match the load requirements. The major disadvantage of this system is relatively poor efficiency particularly at low speeds.(see Figure 10.7)

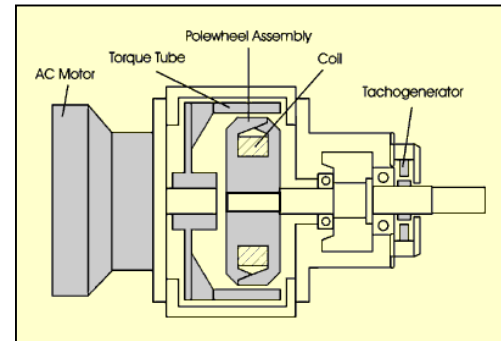

Figure 10.7 Eddy Current Drive

Slip Power Recovery Systems

Slip power recovery is a more efficient alternative speed control mechanism for use with slip-ring motors. In essence, a slip power recovery system varies the rotor voltage to control speed, but instead of dissipating power through resistors, the excess power is collected from the slip rings and returned as mechanical power to the shaft or as electrical power back to the supply line. Because of the relatively sophisticated equipment needed, slip power recovery tends to be economical only in relatively high power applications and where the motor speed range is 1:5 or less.

Fluid Coupling

Fluid coupling is one way of applying varying speeds to the driven equipment, without changing the speed of the motor.

Construction

Fluid couplings (see Figure 10.8) work on the hydrodynamic principle. Inside every fluid coupling are two basic elements – the impeller and the runner and together they constitute the working circuit. One can imagine the impeller as a centrifugal pump and the runner as a turbine. The impeller and the rotor are bowl shaped and have large number of radial vanes. They are suitably enclosed in a casing, facing each other with an air gap. The impeller is connected to the prime mover while the rotor has a shaft bolted to it. This shaft is further connected to the driven equipment through a suitable arrangement.

Thin mineral oil of low viscosity and good-lubricating qualities is filled in the fluid coupling from the filling plug provided on its body. A fusible plug is provided on the fluid coupling which blows off and drains out oil from the coupling in case of sustained overloading.

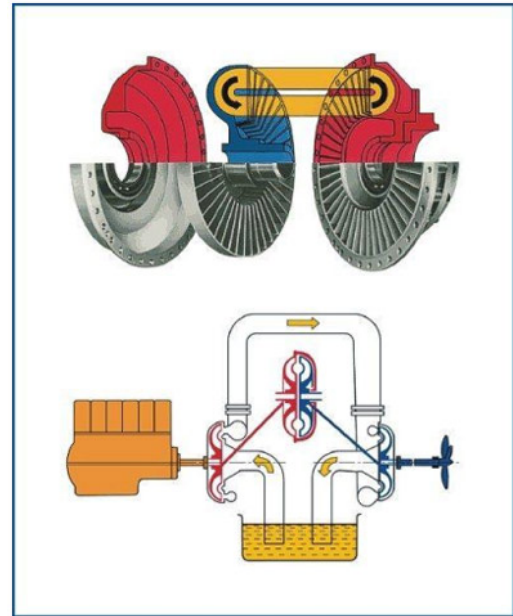

Figure 10.8 Fluid Coupling

Operating Principle

There is no mechanical inter-connection between the impeller and the rotor and the power is transmitted by virtue of the fluid filled in the coupling. When the impeller is rotated by the prime mover, the fluid flows out radially and then axially under the action of centrifugal force. It then crosses the air gap to the runner and is directed towards the bowl axis and back to the impeller. To enable the fluid to flow from impeller to rotor it is essential that there is difference in head between the two and thus it is essential that there is difference in RPM known as slip between the two. Slip is an important and inherent characteristic of a fluid coupling resulting in several desired advantages. As the slip increases, more and more fluid can be transferred. However when the rotor is at a stand still, maximum fluid is transmitted from impeller to rotor and maximum torque is transmitted from the coupling. This maximum torque is the limiting torque. The fluid coupling also acts as a torque limiter.

Characteristics

Fluid coupling has a centrifugal characteristic during starting thus enabling no-load start up of prime mover, which is of great importance. The slipping characteristic of fluid coupling provides a wide range of choice of power transmission characteristics. By varying the quantity of oil filled in the fluid coupling, the normal torque transmitting capacity can be varied. The maximum torque or limiting torque of the fluid coupling can also be set to a pre-determined safe value by adjusting the oil filling. The fluid coupling has the same characteristics in both directions of rotation.

10.6 Energy Efficient Transformers

Most energy loss in dry-type transformers occurs through heat or vibration from the core. The new high-efficiency transformers minimise these losses. The conventional transformer is made up of a silicon alloyed iron (grain oriented) core. The iron loss of any transformer depends on the type of core used in the transformer. However the latest technology is to use amorphous material – a metallic glass alloy for the core (see Figure 10.9). The expected reduction in energy loss over conventional (Si Fe core) transformers is roughly around 70%, which is quite significant. By using an amorphous core– with unique physical and magnetic properties- these new type of transformers have increased efficiencies even at low loads - 98.5% efficiency at 35% load.

Electrical distribution transformers made with amorphous metal cores provide excellent opportunity to conserve energy right from the installation. Though these transformers are a little costlier than conventional iron core transformers, the overall benefit towards energy savings will compensate for the higher initial investment. At present amorphous metal core transformers are available up to 1600 kVA.



Figure 10.9: 1600 kVA Amorphous Core Transformer

10.7 Electronic Ballast

Role of Ballast

In an electric circuit the ballast acts as a stabilizer. Fluorescent lamp is an electric discharge lamp. The two electrodes are separated inside a tube with no apparent connection between them. When sufficient voltage is impressed on these electrodes, electrons are driven from one electrode and attracted to the other. The current flow takes place through an atmosphere of low-pressure mercury vapour.

Since the fluorescent lamps cannot produce light by direct connection to the power source, they need an ancillary circuit and device to get started and remain illuminated. The auxillary circuit housed in a casing is known as ballast.

Conventional Vs Electronic Ballasts

The conventional ballasts make use of the kick caused by sudden physical disruption of current in an inductive circuit to produce the high voltage required for starting the lamp and

then rely on reactive voltage drop in the ballast to reduce the voltage applied across the lamp. On account of the mechanical switch (starter) and low resistance of filament when cold the uncontrolled filament current, generally tend to go beyond the limits specified by Indian standard specifications. With high values of current and flux densities the operational losses and temperature rise are on the higher side in conventional choke.

The high frequency electronic ballast overcomes the above drawbacks. The basic functions of electronic ballast are:

1. To ignite the lamp
2. To stabilize the gas discharge
3. To supply the power to the lamp

The electronic ballasts (see Figure 10.10) make use of modern power semi-conductor devices for their operation. The circuit components form a tuned circuit to deliver power to the lamp at a high resonant frequency (in the vicinity of 25 kHz) and voltage is regulated through an in-built feedback mechanism. It is now well established that the fluorescent lamp efficiency in the kHz range is higher than those attainable at low frequencies. At lower frequencies (50 or 60 Hz) the electron density in the lamp is proportional to the instantaneous value of the current because the ionisation state in the tube is able to follow the instantaneous variations in the current. At higher frequencies (kHz range), the ionisation state cannot follow the instantaneous variations of the current and hence the ionisation density is approximately a constant, proportional to the RMS (Root Mean Square) value of the current. Another significant benefit resulting from this phenomenon is the absence of stroboscopic effect, thereby significantly improving the quality of light output.



Figure 10.10 Electronic Ballast

One of largest advantages of an electronic ballast is the enormous energy savings it provides. This is achieved in two ways. The first is its amazingly low internal core loss, quite unlike old fashioned magnetic ballasts. And second is increased light output due to the excitation of the lamp phosphors with high frequency. If the period of frequency of excitation is smaller than the light retention time constant for the gas in the lamp, the gas will stay ionized and, therefore, produce light continuously. This phenomenon along with continued persistence of the phosphors at high frequency will improve light output from 8-12 percent. This is possible only with high frequency electronic ballast.

10.8 Energy Efficient Lighting Controls

Occupancy Sensors

Occupancy-linked control can be achieved using infra-red, acoustic, ultrasonic or microwave sensors, which detect either movement or noise in room spaces. These sensors switch lighting on when occupancy is detected, and off again after a set time period, when no occupancy movement detected. They are designed to override manual switches and to prevent a situation where lighting is left on in unoccupied spaces. With this type of system it

is important to incorporate a built-in time delay, since occupants often remain still or quiet for short periods and do not appreciate being plunged into darkness if not constantly moving around.

Timed Based Control

Timed-turnoff switches are the least expensive type of automatic lighting control. In some cases, their low cost and ease of installation makes it desirable to use them where more efficient controls would be too expensive (see Figure 10.11).

Types and Features

The oldest and most common type of timed-turnoff switch is the “dial timer,” a spring-wound mechanical timer that is set by twisting the knob to the desired time. Typical units of this type are vulnerable to damage because the shaft is weak and the knob is not securely attached to the shaft. Some spring-wound units make an annoying ticking sound as they operate. Newer types of timed-turnoff switches are completely electronic and silent. Electronic switches can be made much more rugged than the spring-wound dial timer. These units typically have a spring-loaded toggle switch that turns on the circuit for a preset time interval. Some electronic models provide a choice of time intervals, which you select by adjusting a knob located behind the faceplate. Most models allow occupants to turn off the lights manually. Some models allow occupants to keep the lights on, overriding the timer. Timed-turnoff switches are available with a wide range of time spans. The choice of time span is a compromise. Shorter time spans waste less energy but increase the probability that the lights will turn off while someone is in the space. Dial timers allow the occupant to set the time span, but this is not likely to be done with a view toward optimising efficiency. For most applications, the best choice is an electronic unit that allows the engineering staff to set a fixed time interval behind the cover plate.

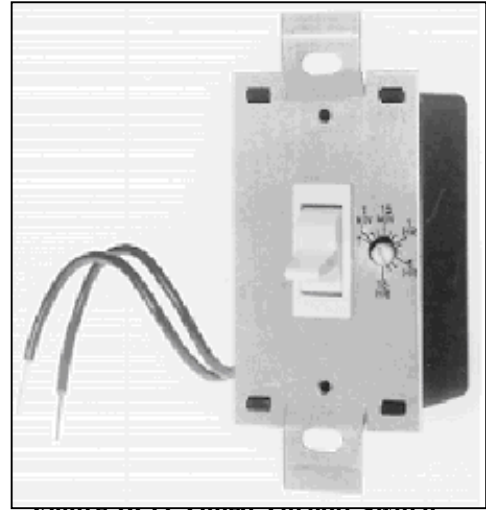

Figure 10.11 Timed Turnoff Switch

Daylight Linked Control

Photoelectric cells can be used either simply to switch lighting on and off, or for dimming. They may be mounted either externally or internally. It is however important to incorporate time delays into the control system to avoid repeated rapid switching caused, for example, by fast moving clouds. By using an internally mounted photoelectric dimming control system, it is possible to ensure that the sum of daylight and electric lighting always reaches the design level by sensing the total light in the controlled area and adjusting the output of the electric lighting accordingly. If daylight alone is able to meet the design requirements, then the electric lighting can be turned off. The energy saving potential of dimming control is greater than a simple photoelectric switching system. Dimming control is also more likely to be acceptable to room occupants.

Localized Switching

Localized switching should be used in applications which contain large spaces. Local switches give individual occupants control over their visual environment and also facilitate energy savings. By using localized switching it is possible to turn off artificial lighting in specific areas, while still operating it in other areas where it is required, a situation which is impossible if the lighting for an entire space is controlled from a single switch.

QUESTIONS	
1.	Explain how maximum demand control works.
2.	Explain the principle of automatic power factor controller .
3.	What are the advantages of energy efficient motors?
4.	What are the precautions to be taken in the case of energy efficient motor application ?
5.	Explain the working of a soft starter and its advantage over other conventional starters.
6.	Explain why centrifugal machines offers the greatest savings when used with Variable Speed Drives.
7.	Hydrodynamic principle for speed control is used in a) DC drives b) Fluid coupling c) Pulse width modulation d) Eddy Current Drive
8.	Typical loss in conventional magnetic chokes for a 40 W FTL is of the order of a) 8 Watts b) 14 Watts c) 20 Watts d) 6 Watts
9.	Which method uses infrared, acoustic, ultrasonic or microwave sensors for lighting control? a) Time-based control b) Daylight-linked control c) Occupancy-linked control d) Localized switching
10.	Slip Power Recovery system is used in a) All kinds of motors b) Synchronous motors c) Slip – Ring Induction motor d) None of the above

REFERENCES

1. Energy Management Supply and Conservation, Butterworth Heinemann, 2002 – Dr. Clive Beggs.
2. Handbook of Energy Engineering, The Fairmont Press, INC. – Albert Thumann & Paul Mehta.